

HORNTONES

GIVE YOUR RIDE A VOICE!

FH 550

HORNTONES SYSTEM

Owner's Manual

UG-FX550 Rev A2

TABLE OF CONTENTS

1	Introduction	3
2	What's in the Box	3
3	Installation	4
3.1	Installation Preparation	4
3.2	Player Installation	4
3.2.1	Mounting the Player	4
3.2.2	The Player Cable	5
3.3	Amplifier Installation	7
3.3.1	Power & Speaker Connection	7
3.4	Sounder Installation	8
4	Using Your System	9
4.1	Naming Your Player	9
4.2	Pre- Installed Tones	9
4.3	Adding new tones	9
4.4	Custom tones	10
5	Limited Warranty	10
6	Legal Disclosure	11

1 INTRODUCTION

Congratulations on your purchase of the Horntones FX-550 system, the first mobile audio system that allows you to supplement the sound of your vehicle's horn function using virtually any standard audio file!

2 WHAT'S IN THE BOX

Your Horntones FX-550 system includes the following items. Please check to be sure that you have everything.

1. One Horntones Player, Model FX-550, including mounting bracket and two thumbscrews.
2. One player cable.
3. One audio amplifier, Model AP-150.
4. One Horntones Sounder, Model SR-100.
5. This User Guide.

3 INSTALLATION

IMPORTANT: It is recommended that you have a professional audio installer install your Horntones FX-550 system. Horntones will not be responsible for damaged components due to improper installation.

3.1 INSTALLATION PREPARATION

Before installing any FX-550 components, disconnect the positive terminal from your vehicles battery.

3.2 PLAYER INSTALLATION

Installing the FX-550 player consists of two steps described in the following sections:

3.2.1 Mounting the Player

First, determine the location for the FX-550. It can be mounted on, in or under the dash or any other convenient location. The U bracket is provided to facilitate securing the unit to the desired location.

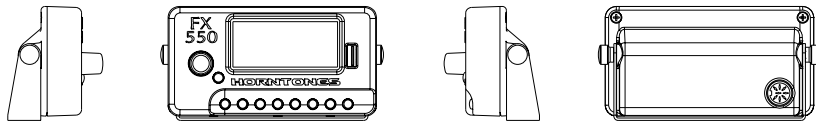

3.2.2 The Player Cable

The following diagram describes the cable connection of the FX-550 to the rest of the system:

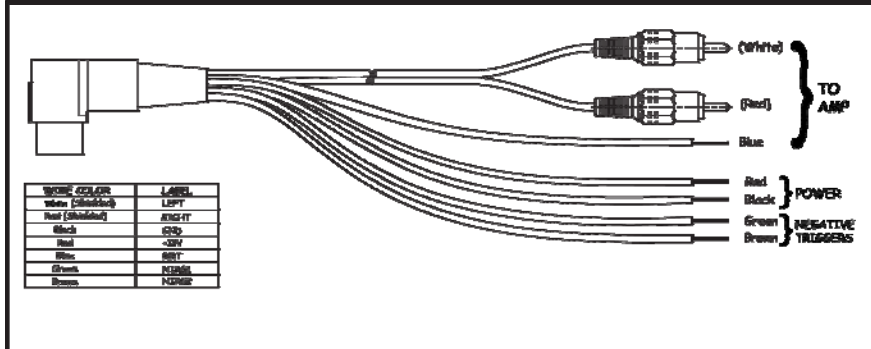

3.2.2.1 Power Connections

Connect the **RED (+12V)** wire to a battery voltage source that is energized when the ignition is turned on.

***Note:** The player is turned on whenever +12V is applied to the RED wire. You should not connect the RED wire to a power source that is a direct connection to the battery, as your player will never turn off.*

Connect the **BLACK (GND)** wire to **Ground**.

3.2.2.2 Amplifier Connections

Connect the **RED JACK (RIGHT)** to the amplifier's **Right** Line In connector.

Connect the **WHITE JACK (LEFT)** to the amplifier's **Left** Line In connector.

Connect the **BLUE (REM)** to the amplifier's **Remote (REM)** input.

***Note:** Depending on the installation location of the Player and the Amp, Extension wires may be needed.*

3.2.2.3 Negative Trigger Connections

NEGATIVE TRIGGER 1 (NTRG1) and **NEGATIVE TRIGGER 2 (NTRG2)** can be used to sound a horn tones when connected to a negative trigger source such as a car alarm or a remote switch. The following diagram shows connection to a remote switch.

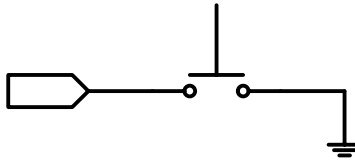

3.3 AMPLIFIER INSTALLATION

3.3.1 Power & Speaker Connection

The following diagram shows the connection to the AP-150 amplifier and SR-100 Sounder.

Note: Once your FX-550 system is installed, it will be necessary to adjust the amplifier gain to set the proper volume.

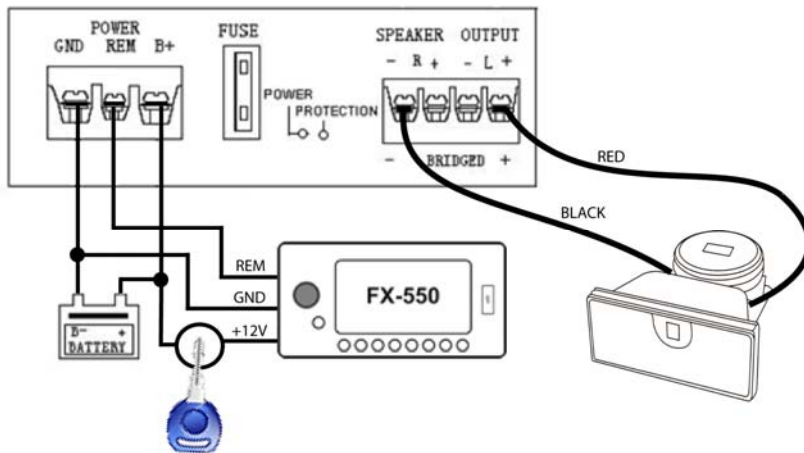

Note: See amplifier documentation for detailed amplifier installation instructions.

3.4 SOUNDER INSTALLATION

The sounder mounting is the most challenging part of the horn tones system installation. It is important to select the proper location for the Sounder. For optimum performance, the sounder should be located under the hood or underneath the vehicle with the sound projecting forward.

The SR-100 sounder is complete with a pre-attached mounting bracket and 4 mounting screws. Although for most installations the SR-110 will mount directly to a flat panel, a bit of custom fabrication may be required to mount your SR-100 in the perfect location.

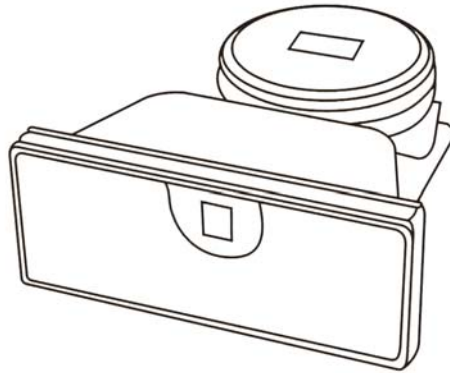

4 USING YOUR SYSTEM

4.1 NAMING YOUR PLAYER

When you first power up your FX-550 you will be prompted to give your FX-550 a Name. Naming your player will help facilitate transferring new tones from the horntones.com website to your player. Please select an 8 character nickname. You will need this nickname when configuring your player on-line. For example: HUMMER01, MACHFIVE...

***Note:** Use the control dial to select characters; press the dial to select desired character.*

4.2 PRE-INSTALLED TONES

Your FX-550 system is pre-programmed with two Themes: HORNS and VOICES. To switch between HORNS and VOICES, choose the Theme option using the control dial.

4.3 ADDING NEW TONES

Additional horntones are available from horntones.com. There, you will be able to select new tones and be able to configure the buttons on your player on-line as well. Please go on-line to view instructions on how to add tones to and configure your FX-550 player.



4.4 CUSTOM TONES

You can use any audio editing program that creates MP3 files to generate new tones. Your new tones are then uploaded into your horntones account on horntones.com and are then compiled into a format recognized by the FX-550 player. Please visit horntones.com for more information.

***Note:** Horntones audio files must be compiled for use in the horntones system. Custom mp3 horntones must be uploaded into your horntones.com account. There you can assign them to Themes/Presets. New Tones are then compiled and saved onto your USB thumb-drive in a format recognized by the FX-550 player.*

5 LIMITED WARRANTY

The Horntones FX-550 system is warranted for one year against defects in workmanship and materials from the original date of purchase.

Horntones will repair or replace any Horntones unit which proves to be defective in workmanship or material under reasonable use during this period.

6 LEGAL DISCLOSURE

The Horntones FX-550 system is intended to personalize your vehicle with entertaining sounds which may supplement your vehicle's horn function.

The FX-550 system creates high fidelity audible sounds that emanate from your vehicle. Considering that these sounds can propagate into the near-by traffic and pedestrian space, the system must be used in accordance with prevailing state and local motor vehicle codes, as well as in such a way as common courtesy would dictate.

Bells, sirens and whistles MUST NEVER be used as horntones, as these are illegal and reserved for emergency use by police cars, fire engines, ambulances and emergency vehicles.

The FX-550 is not a replacement for your vehicle factory horn. Your standard vehicle horn should be used for alerting of ALL dangerous situations.

